



memmert
Experts in Thermostatics

Heating and drying ovens

COMMUNICATION. COMFORT. SIMPLY GREAT.

UNIVERSAL OVEN U
PASS-THROUGH OVEN UFP TS
PARAFFIN OVEN UNpa
STERILISER S
VACUUM OVEN VO
COOLED VACUUM OVEN VOcool

100% ATMOSAFE. MADE IN GERMANY.

www.memmert.com | www.atmosafe.net

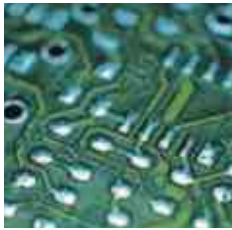

Simply boundless. Boundlessly simple.

Drying, heating, ageing, testing, sterilising,
burning-in, testing, curing, storing. 100% AtmoSAFE.

From very small to very large! 32 litres or 1060 litres chamber volume? Standard applications or high demand for functionality, programming and documentation? In any case, all Memmert heating and drying ovens feature user-friendliness and state-of-the-art communication interfaces as a basic. Each individual appliance complies with the strict requirements of DIN 12 880: 2007-05 and is equipped with a maximum of safety functions. Each individual Memmert heating and drying oven is 100% AtmoSAFE.



UNIVERSAL OVEN U

PAGE 4 TO 5

TECHNICAL DATA

PAGE 6 TO 7

Drying, burning-in, ageing, vulcanising, degassing,
curing, burn-in testing, conditioning, heated storage

PASS-THROUGH OVEN UFP TS

PAGE 8 TO 9

TECHNICAL DATA

PAGE 10 TO 11

In-line curing and tempering

HOT AIR STERILISER S

PAGE 12 TO 13

TECHNICAL DATA

PAGE 14 TO 15

Sterilising of instruments and laboratory glass

PARAFFIN OVEN UNpa

PAGE 16 TO 17

TECHNICAL DATA

PAGE 18 TO 19

Tempering of embedding media like paraffin and wax

VACUUM OVEN VO

PAGE 20 TO 21

TECHNICAL DATA

PAGE 22 TO 23

Drying, burning-in, ageing, curing, degassing,
conditioning, oxygen-free storing

COOLED VACUUM OVEN VOcool

PAGE 24 TO 25

TECHNICAL DATA

PAGE 26 TO 27

Drying, burning-in, ageing, curing, degassing,
conditioning, oxygen-free storing

SOFTWARE GENERATION 2012

PAGE 28

AtmoCONTROL software

OPTIONS AND ACCESSORIES

PAGE 28 TO 30

Available for all products of Generation 2012 and 2003

GENERATION 2012

PAGE 31

Features of model variants SingleDISPLAY and TwinDISPLAY



GENERATION 2012

Universal Oven UN and UF with SingleDISPLAY
Universal Oven UNplus and UFplus with TwinDISPLAY
Natural convection or forced ventilation
AtmoCONTROL software

Model sizes:

30 / 55 / 75 / 110 / 160 / 260 / 450 / 750 / 1060
+30 °C up to +300 °C

UNIVERSAL OVEN U The all-round genius among the heating ovens cover a multitude of applications, ideally at temperatures above +50 °C. Without compromises! Thanks to two model variants and eight sizes, optionally with natural or forced convection, industry, science and research institutes will find a heating and drying oven which combines top precision and safety with optimal operating comfort.



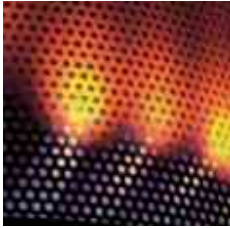

Defined and programme-controlled fan speed

Air exchange rates and air flap position can be controlled electronically at the ControlCOCKPIT. More inlet and outlet openings lead to a higher air exchange and reduced drying times. Various applications recommend or even require controlled ventilation. When drying powder, sand or corn, reducing the ventilation prevents undesired swirls.

Other applications like testing of wires or cables demand for defined air exchange rates. UFplus appliances feature easy programming of temperature and air exchange rates with the AtmoCONTROL software.

Fresh air is preheated

Temperature deviations caused by fresh air can influence sample characteristics or prolong drying. In Memmert universal ovens, the fresh air is therefore fed through a pre-heating chamber and introduced into the working chamber.

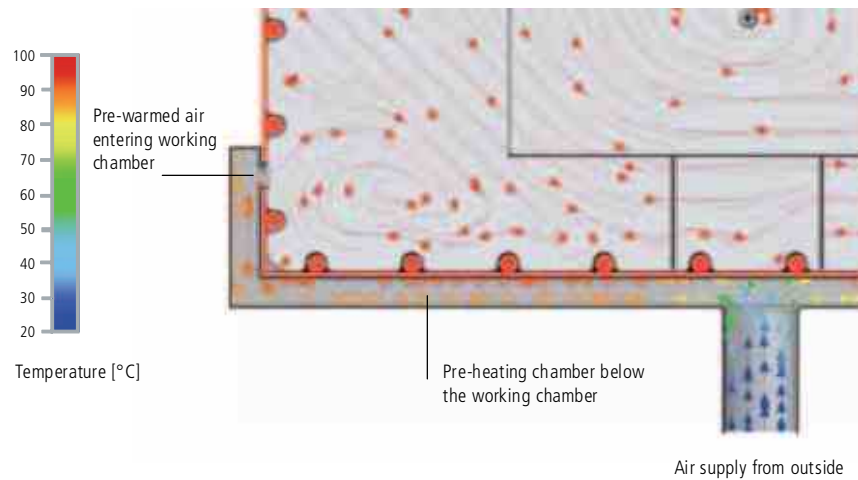

Intended purpose as a medical device:

Heating ovens UF (with extended overtemperature protection – option A6) and UFplus are applied for heating of non-sterile fabrics and covers.



UNIVERSAL OVENS U

according to DIN 12 880: 2007-05, EN 61010-1 (IEC 61010-1), 61010-2-010

Standard units are safety-approved and bear the test marks:



Standard equipment

- Interior: Stainless steel, material 1.4301 (ASTM 304), with all-round deep-drawn ribs to integrate the large-area heating with ceramic-metal sheath
- Internals: Stainless steel grids (sizes 30, 55 and 1060: 1 grid, sizes 75 – 750: 2 grids)
- Housing: Textured stainless steel, rear zinc-plated steel, intuitively operated SingleDISPLAY or TwinDISPLAY (TFT colour display) with Touchscreen (from size 450 two leaves)
- Fresh air: Admixture of pre-heated fresh air by electronically adjustable air flap
- Connection: Mains cable with plug (German type) CEE plug for 400 V
- Installation: 4 feet; sizes 450, 750 and 1060 mounted on lockable castors
- Interfaces:



(only TwinDISPLAY)

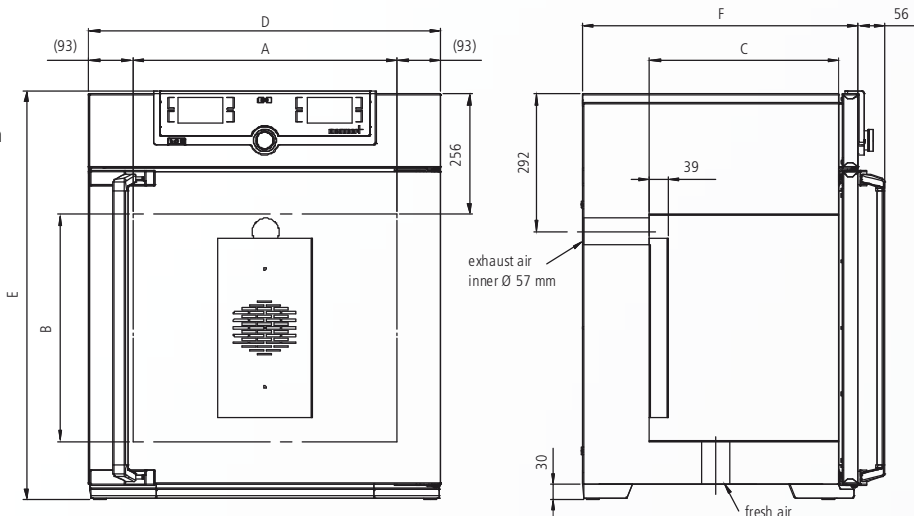

Model sizes/Description			30	55	75	110	160	260	450	750	1060	
Stainless steel interior	Volume	approx. l	32	53	74	108	161	256	449	749	1060	
	Width	(A) mm	400	400	400	560	560	640	1040	1040	1040	
	Height	(B) mm	320	400	560	480	720	800	720	1200	1200	
	Depth (less 39 mm for fan)	(C) mm	250	330	330	400	400	500	600	600	850	
	Stainless steel grids (standard equipment)	number	1			2					1	
	Max. number of grids/shelves	number	3	4	6	5	8	9	8	14	14	
	Max. loading per grid/shelf	kg	20							30	60	
Max. loading of chamber	kg	60	80	120	175	210	300					
Textured stainless steel exterior	Width	(D) mm	585	585	585	745	745	824	1224	1224	1224	
	Height (size 450, 750, 1060 with castors)	(E) mm	704	784	944	864	1104	1183	1247	1726	1726	
	Depth (without door handle), door handle + 56 mm	(F) mm	434	514	514	584	584	684	784	784	1035	
Further data	Electrical load at 230 V, 50/60 Hz	approx. W	1600	2000	2500	2800	3200	3400	-			
	Electrical load at 115 V, 50/60 Hz	approx. W	1600	1700	2200					-		
	Electrical load at 400 V and 3 x 230 V w/o neutral, 50/60 Hz	approx. W	-							5800	7000	
	Working-temperature range	°C	at least 5 (UN/UNplus) at least 10 (UF/UFplus) above ambient temperature to +300									
	Setting temperature range	°C	+20 to +300									
	Setting accuracy	°C	up to 99.9: 0.1 / from 100: 0.5									
Packing data	Net weight	approx. kg	48	57	66	78	96	110	170	217	305	
	Gross weight (packed in carton)	approx. kg	64	78	87	103	122	161	236	288	390	
	Width	approx. cm	66	73	73	83	83	93	133	133	133	
	Height	approx. cm	89	97	112	106	130	153	145	192	192	
	Depth	approx. cm	65	67	67	80	80	93	105	105	126	
Order No. Universal Ovens U = Universal Oven N = Natural convection F = Forced air circulation plus = Model with TwinDISPLAY			UN30	UN55	UN75	UN110	UN160	UN260	UN450	UN750	-	
			UN30plus	UN55plus	UN75plus	UN110plus	UN160plus	UN260plus	UN450plus	UN750plus	-	
			UF30	UF55	UF75	UF110	UF160	UF260	UF450	UF750	UF1060	
			UF30plus	UF55plus	UF75plus	UF110plus	UF160plus	UF260plus	UF450plus	UF750plus	UF1060plus	