

B026-05N
PAVEMIX**AUTOMATIC ASPHALT LARGE LABORATORY MIXER, 32 LITRES CAPACITY**

STANDARD: EN 12697-35

The PaveMix has been expressly designed to prepare homogeneous bituminous mixtures at a strictly controlled temperature. The preparation of the bituminous mixture is obtained in a short time period (few minutes) to avoid any mechanical aggregate degradation and to fully coat all mineral components, as requested by EN 12697-35.

The helical mixing blades are detachable to facilitate the cleaning procedure.

MAIN FEATURES

- Mixing capacity: 32 litres max.
- Mixing bowl: stainless steel AISI 316.
- Slot on the top of the lid to pour filler and additives during mixing.
- Mixing temperature: selectable from ambient up to 260 °C through sensitive probe and digital display control.
- Mixing speed: adjustable from 4 to 40 rpm.
- Easy tilting unloading operation by electromechanical motion with rotation up to 130°.
- Strictly controlled temperature.
- Fast preparation of bituminous samples.
- Detachable mixing blades to facilitate the cleaning and maintenance procedure.

**B026-05N**

The Pavemix produces bituminous mixtures to perform:

- Gyrotory compaction tests (EN 12697-10, EN 12697-31)
- Marshall stability tests (EN 12697-34, EN 13108)
- Wheel tracking wet and dry tests (EN 12697-22)
- Slabs compaction laboratory tests (EN 12697-33)
- Beam fatigue and Stiffness tests (EN 12697-26, EN 13108)
- Asphalt general purpose tests.

PaveMix consists of:

- Main frame holding a horizontal stainless steel bowl with a helical mixing shaft.
- The bowl, double wall insulation made of stainless steel AISI 316, contains an electric heater with probe sensor granting constant and uniform temperature control.
- **An electromechanical motion allows to tilt the bowl facilitate the unloading operation, with total rotation up to 130°.**

The control panel foresees:

- Digital thermo regulator to set temperature and to control the mixing temperature.
- Mixing speed regulator.
- Main and start/stop switches.
- Rotation inversion of the blades.
- Command to tilt the bowl.

Heating power: 3000W

Power supply: 230V 1ph 50-60Hz 4500W

Dimensions: 1280x700x1210 mm

Weight: 350 kg approx.

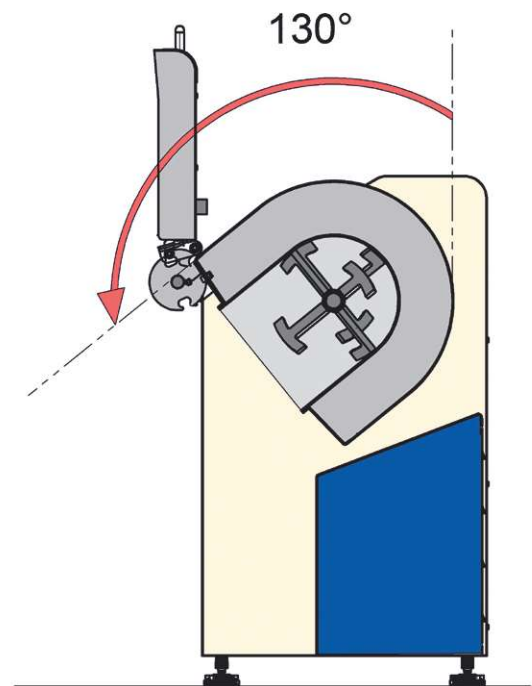

Unloading procedure.

Easy tilting of the bowl by electric motion with rotation angle up to 130°

ACCESSORY

B026-10N COLLECTING PAN



B026-10N



Detail of the detachable mixing shaft with helical blades



Detail: slot on the top of the lid

